

## General Description

BDE-BD2564CA is a Bluetooth 5.1 BR/EDR & LE dual mode transceiver module.

The module integrates Bluetooth classic and Bluetooth Low Energy radio TI's CC2564C, a 26-MHz crystal oscillator, a band pass filter, a fine-tuned chip antenna and all the passive components at a very affordable cost.



The module provides the best-in-class RF performance with transmit power and receive sensitivity that provides twice the range and higher throughput than other Bluetooth-low-energy-only solutions. The power-management hardware and software algorithms provide significant power savings in all commonly used Bluetooth BR/EDR and low energy modes of operation.

The certified and royalty free Dual-mode Bluetooth 5.1 protocol stack software provides a complete Bluetooth BR/EDR, and Bluetooth Low Energy sample applications that reduce design effort and ensure a faster time to market.

The module has a very small form factor with the dimensions of 7 mm x 14 mm x 1.55 mm.

## Key Features

- Bluetooth 5.1 dual mode
  - Bluetooth Basic Rate (BR)
  - Enhanced Data Rate (EDR)
  - Low Energy (LE)
- BR and EDR features include:
  - Up to seven active devices
  - Scatternet: Up to three piconets simultaneously, one as master and two as slaves
  - Up to two Synchronous Connection Oriented (SCO) links on the same piconet
  - Support for all voice air-coding – continuously Variable Slope Delta (CVSD), A-Law,  $\mu$ -Law, modified Subband Coding (mSBC), and transparent (Uncoded)
  - Provide an assisted mode for HFP 1.6 Wideband Speech (WBS) profile or A2DP profile to reduce host processing and power
  - Support of multiple Bluetooth profiles with enhanced QoS
- Low Energy features include:
  - Multiple sniff instances tightly coupled to achieve minimum power consumption
  - Independent buffering for Low Energy allows large numbers of multiple connections without affecting BR or EDR performance
- Best-in-Class Bluetooth (RF) performance (TX power, RX sensitivity, blocking)
  - Built-In coexistence and prioritization handling for BR, EDR, and Low Energy
  - Capabilities of link layer topology, Scatternet - can act concurrently as peripheral and central
  - Network support for up to 10 devices
  - Time line optimization algorithms to achieve maximum channel utilization
- Advanced power management for extended battery life and ease of design
  - On-Chip power management, including direct connection to battery
  - Low power consumption for active, standby, and scan Bluetooth modes

- Shutdown and sleep modes to minimize power consumption
- Physical interfaces:
  - UART Interface with support for maximum Bluetooth data rates
  - UART transport layer (H4) with maximum rate of 4 Mbps
  - Three-Wire UART transport layer (H5) with maximum rate of 4 Mbps
  - Fully programmable Digital Pulse-Code Modulation (PCM) - I2S codec interface
- Flexibility for easy stack integration and validation
  - into MCUs and MPUs
  - HCI tester tool to evaluate RF performance of the device and configure service pack
  - Antenna: chip antenna, 0.5 dBi gain
  - Size: 7 mm x 14 mm x 1.55 mm (With Shield)
  - Standards Conformance
    - *Bluetooth*® SIG
    - CE-RED (Europe)
    - FCC (US)
    - ISED (Canada)
    - Japan (Telec)

### Applications

- Mobile Accessories
- Sports and Fitness Applications
- Wireless Audio Solutions
- Set-Top Boxes and Remote Controls
- Toys
- Test and Measurement
- Industrial: Cable Replacement
- Wireless Sensors
- Automotive Aftermarket
- Wellness and Health

## Contents

General Description .....	1
Key Features .....	1
Applications .....	3
Contents .....	4
1. Block Diagram .....	5
2. Pinout .....	6
3. Characteristics .....	7
3.1. Absolute Maximum Ratings .....	7
3.2. Recommended Operating Conditions .....	8
3.3. Current Consumption .....	8
3.3.1 Static Current Consumption .....	8
3.3.2 Dynamic Current Consumption .....	8
3.4. RF performance .....	9
3.4.1 Bluetooth BR and EDR RF Performance .....	9
4. Mechanical Specifications .....	10
4.1. Dimensions .....	10
4.2. PCB Footprint .....	12
5. Marking .....	12
6. Reference Design and Guidelines .....	13
6.1. Block Diagram .....	13
6.2. Reference Schematic .....	13
6.3. Layout Guidelines .....	14
6.3.1 General guidelines .....	14
6.3.2 Module Placement .....	15
7. Certification .....	15
7.1. FCC Warning and Statement .....	15
7.2. IC Statement .....	17
7.3. Module Statement .....	18
8. Ordering Information .....	19
9. Revision History .....	19
Important Notice and Disclaimer .....	20
Contact .....	20

# 1. Block Diagram

BDE-BD2564CA integrates Bluetooth classic and Bluetooth Low Energy radio TI's CC2564C, a 26-MHz crystal oscillator, a band pass filter, a fine-tuned chip antenna and all the passive components at a very affordable cost.

Figure 1-1 shows the block diagram of the module.

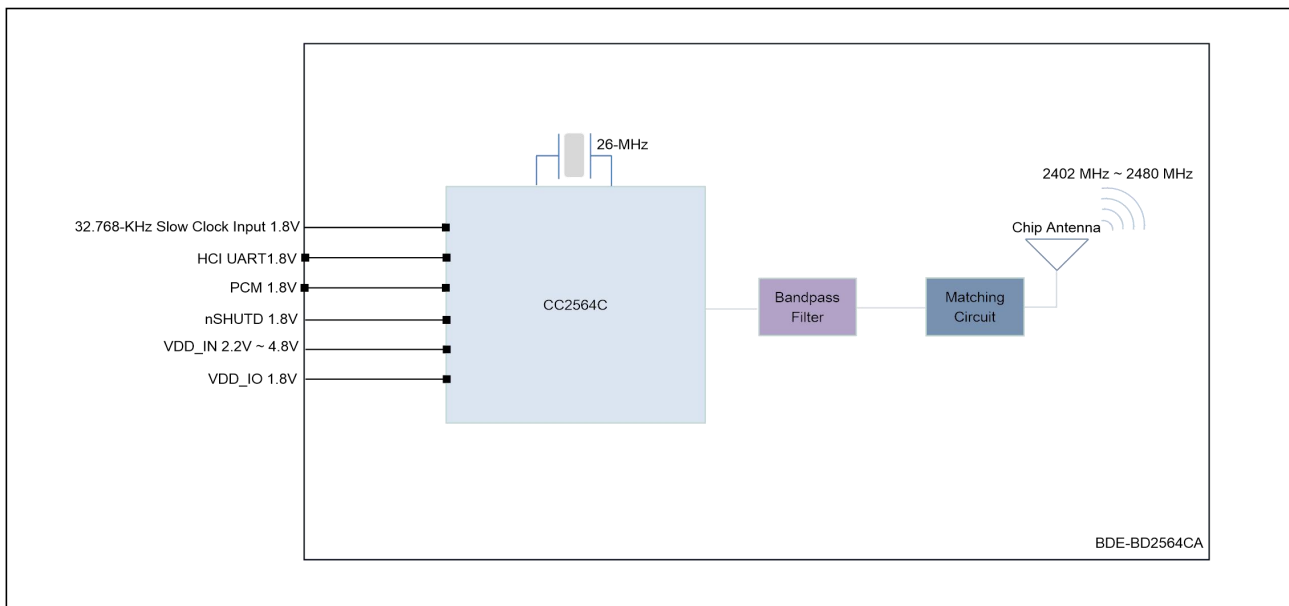

Figure 1-1. The block diagram of BDE-BD2564CA

## 2. Pinout

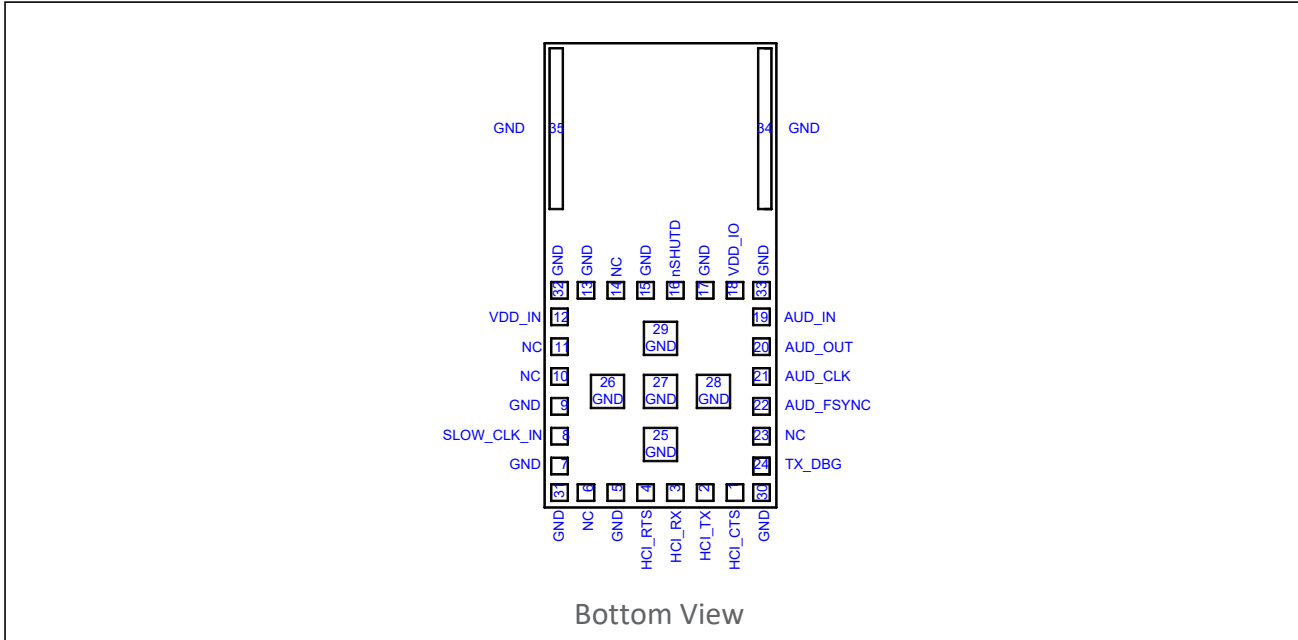

Figure 2-1. Pinout Diagram Bottom View

Table 2-1 describes the definitions of the pins.

Table 2-1. Pin Description

Pin #	Pin Name	Type	Description
1	HCI_CTS	DI <sup>(Note 1)</sup> , PU <sup>(Note 2)</sup>	HCI UART clear-to-send. The device can send data when HCI_CTS is low
2	HCI_TX	DO, PU	HCI UART data transmit
3	HCI_RX	DI, PU	HCI UART data receive
4	HCI_RTS	DO, PU	HCI UART request-to-send. Host can send data when HCI_RTS is low
5	GND	GND	Power ground
6	NC	-	Not connected
7	GND	GND	Power ground
8	SLOW_CLK_IN	DI	32.768-kHz clock in, fail-safe
9	GND	GND	Power ground
10	NC	-	Not connected
11	NC	-	Not connected
12	VDD_IN	Power	Main power supply for the module (2.2 to 4.8 V)
13	GND	GND	Power ground
14	NC	-	Not connected
15	GND	GND	Power ground
16	nSHUTD	DI, PD	Shutdown input (active low)
17	GND	GND	Power ground

Pin #	Pin Name	Type	Description
18	VDD_IO	Power	I/O power supply (1.8 V nominal)
19	AUD_IN	DI, PD	PCM data input, fail-safe
20	AUD_OUT	DO, PD	PCM data onput, fail-safe
21	AUD_CLK	DIO <sup>(Note 1)</sup> , PD	PCM clock, fail-safe
22	AUD_FSYNC	DIO, PD	PCM frame sync, fail-safe
23	NC	-	Not connected
24	TX_DBG	DO, PU	Internal debug messages
25	GND	GND	Power ground
26	GND	GND	Power ground
27	GND	GND	Power ground
28	GND	GND	Power ground
29	GND	GND	Power ground
30	GND	GND	Power ground
31	GND	GND	Power ground
32	GND	GND	Power ground
33	GND	GND	Power ground

Note 1: DI stands for Digital Input, DO stands for Digital Output, DIO stands for Digital Input-Output;

Note 2: PU stands for internal Pull-Up, PD stands for internal Pull-Down.

### 3. Characteristics

All MIN/MAX specification limits are guaranteed by design, production testing and/or statistical characterization. Typical values are based on characterization results at default measurement conditions and are informative only.

Default measurement conditions (unless otherwise specified): VDD\_IN = 3.6 V, VDD\_IO = 1.8V, TA = 25 °C. All radio measurements are performed with standard RF measurement equipment.

#### 3.1. Absolute Maximum Ratings

Stresses beyond those listed under Absolute Maximum Ratings may cause permanent damage to the device. These are stress ratings only, so functional operation of the device at these or any other conditions beyond those indicated in the operational sections of the specification are not implied. Exposure to Absolute Maximum Rating conditions for extended periods may affect device reliability.

Table 3-1. Absolute Maximum Ratings

PARAMETER	MIN	MAX	UNIT	Notes
VDD_IN	-0.5	4.8	V	
VDD_IO	-0.5	2.415	V	
Input voltage to analog pin	-0.5	2.1	V	BT_ANT
Input voltage to all other pins	-0.5	VDD_IO + 0.5		
Bluetooth RF pin		10	dBm	
Storage Temperature	-40	100	°C	

## 3.2. Recommended Operating Conditions

Table 3-2. Recommended Operating Conditions

PARAMETER	MIN	TYP	MAX	UNIT
VDD_IN	2.2		4.8	V
VDD_IO	1.62		1.92	V
Operating Temperature	-40	-	85	°C

## 3.3. Current Consumption

### 3.3.1 Static Current Consumption

Table 3-3. Static Current Consumption

OPERATIONAL MODE	MIN	TYP	MAX	UNIT	Notes
Shutdown mode		1	7	uA	
Deep sleep mode		40	105	uA	
Total I/O current consumption in active mode			1	mA	
Continuous transmission—GFSK			107	mA	At maximum output power
Continuous transmission—EDR			112.5	mA	At maximum output power

### 3.3.2 Dynamic Current Consumption

Table 3-4. Current Consumption for Different Bluetooth BR and EDR Scenarios

OPERATIONAL MODE	MASTER AND SLAVE	AVERAGRE CURRENT	UNIT
SCO link HV3	Master and slave	13.7	mA
Extended SCO (eSCO) link EV3 64 kbps, no retransmission	Master and slave	13.2	mA
eSCO link 2-EV3 64 kbps, no retransmission	Master and slave	10	mA
GFSK full throughput: TX = DH1, RX = DH5	Master and slave	40.5	mA
EDR full throughput: TX = 2-DH1, RX = 2-DH5	Master and slave	41.2	mA
EDR full throughput: TX = 3-DH1, RX = 3-DH5	Master and slave	41.2	mA
Sniff, four attempts, 1.28 seconds	Master and slave	145	uA
Page or inquiry scan 1.28 seconds, 11.25 ms	Master and slave	320	uA
Page (1.28 seconds) and inquiry (2.56 seconds) scans, 11.25 ms	Master and slave	445	uA
A2DP source	Master	13.9	mA
A2DP sink	Master	15.2	mA
Assisted A2DP source	Master	16.9	mA
Assisted A2DP sink	Master	18.1	mA



OPERATIONAL MODE	MASTER AND SLAVE	AVERAGRE CURRENT	UNIT
Assisted WBS EV3; retransmit effort = 2; maximum latency = 8 ms	Master and slave	17.5 and 18.5	mA
Assisted WBS 2EV3; retransmit effort = 2; maximum latency = 12 ms	Master and slave	11.9 and 13	mA

**Table 3-5. Current Consumption for Different BLE Scenarios**

OPERATIONAL MODE	DESCRIPTION	AVERAGRE CURRENT	UNIT
Advertising, nonconnectable	Advertising in all three channels 1.28-seconds advertising interval 15 bytes advertise data	114	uA
Advertising, discoverable	Advertising in all three channels 1.28-seconds advertising interval 15 bytes advertise data	138	uA
Scanning	Listening to a single frequency per window 1.28-seconds scan interval 11.25-ms scan window	324	uA
Connected	Master role	169	uA
	Slave role	199	

### 3.4. RF performance

#### 3.4.1 Bluetooth BR and EDR RF Performance

**Table 3-6. Bluetooth RX**

CHARACTERISTICS	MIN	TYP	MAX	UNIT
Operation frequency range	2402		2480	MHz

Channel spacing	1	MHz
Input Impedance	50	ohm
Sensitivity—GFSK, BER = 0.1%	-93	dBm
Sensitivity— $\pi$ /4-DQPSK, BER = 0.01%	-92	dBm
Sensitivity—8DPSK, BER = 0.01%	-85	dBm

**Table 3-7. Bluetooth TX**

CHARACTERISTICS	MIN	TYP	MAX	UNIT
TX power—GFSK		8		dBm
TX power— $\pi$ /4-DQPSK		8		dBm
TX power—8DPSK		8		dBm

**Table 3-8. Bluetooth Low Energy RX**

CHARACTERISTICS	MIN	TYP	MAX	UNIT
Operation frequency range	2402		2480	MHz
Channel spacing		2		MHz
Input Impedance		50		ohm
Sensitivity—GFSK, PER = 30.8%		-93		dBm

**Table 3-9. Bluetooth TX**

CHARACTERISTICS	MIN	TYP	MAX	UNIT
TX power—GFSK		8		dBm

## 4. Mechanical Specifications

### 4.1. Dimensions

The module dimensions are presented in the following figure:

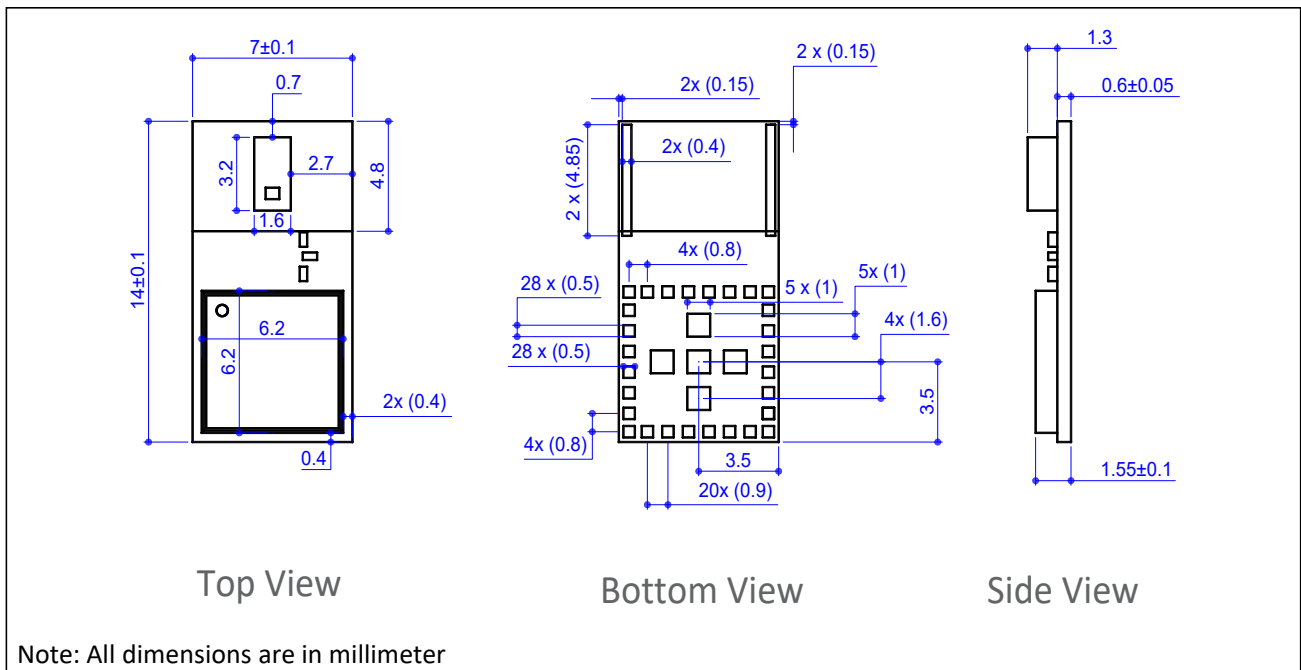

Figure 4-1. Mechanical Drawing

### 4.2. PCB Footprint

The footprint for the PCB is presented in the following figure:

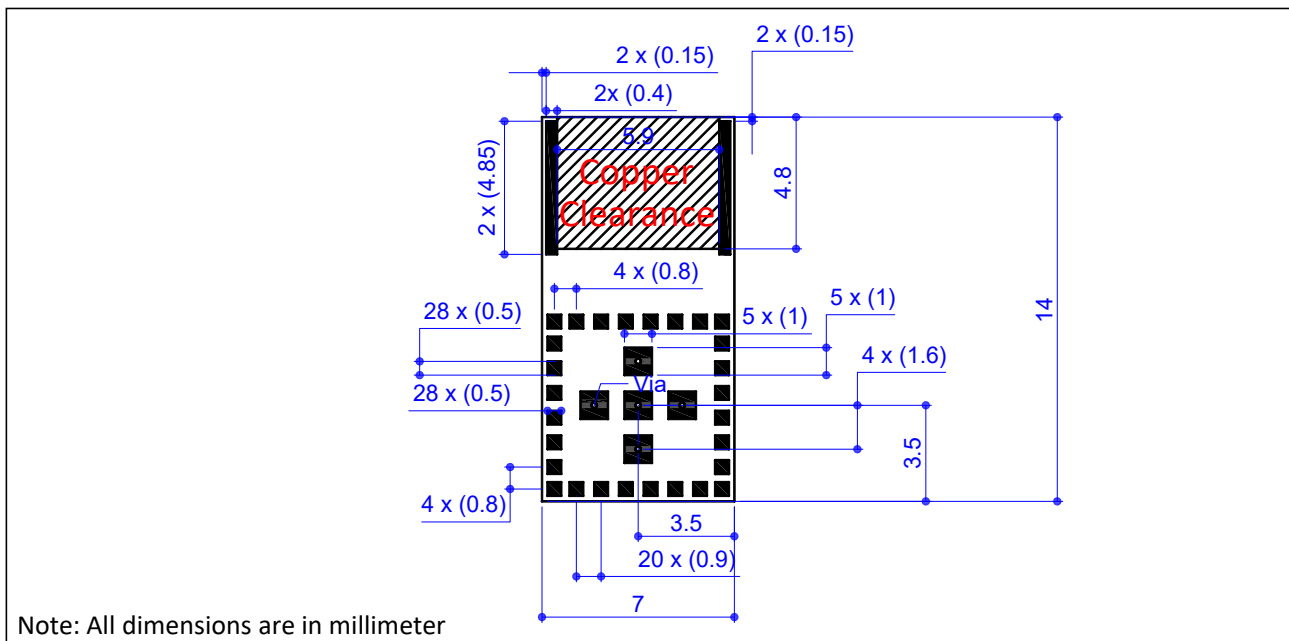

Figure 4-2. Module Footprint Top View

### 5. Marking

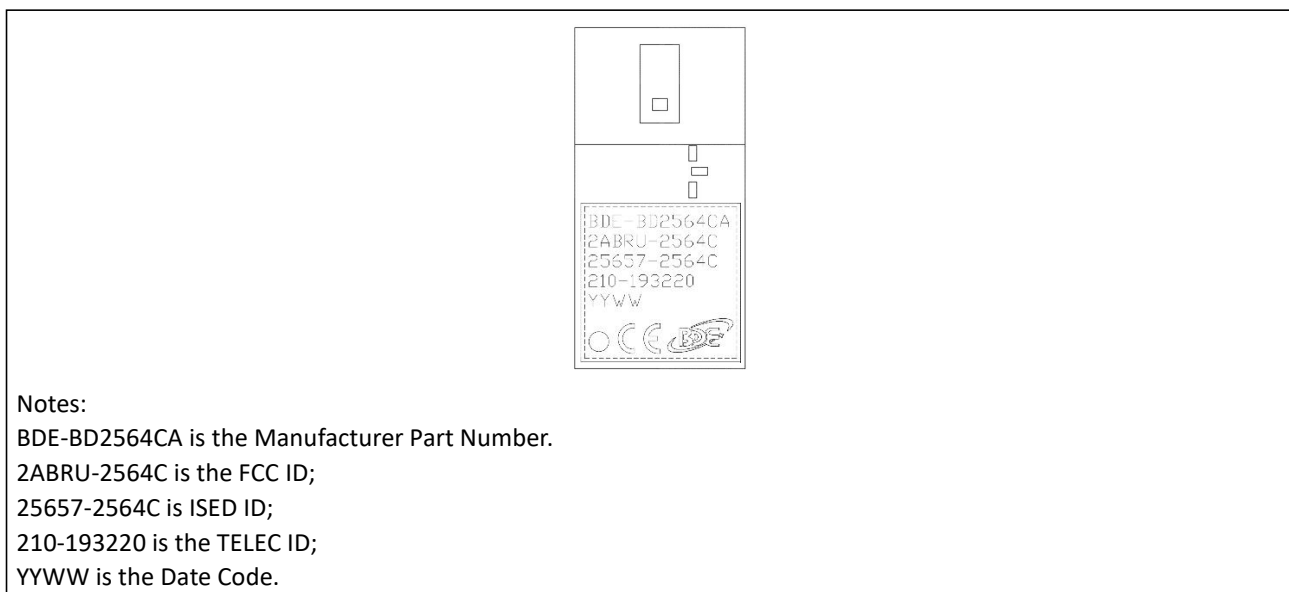

Figure 5-1. Module Marking

## 6. Reference Design and Guidelines

### 6.1. Block Diagram

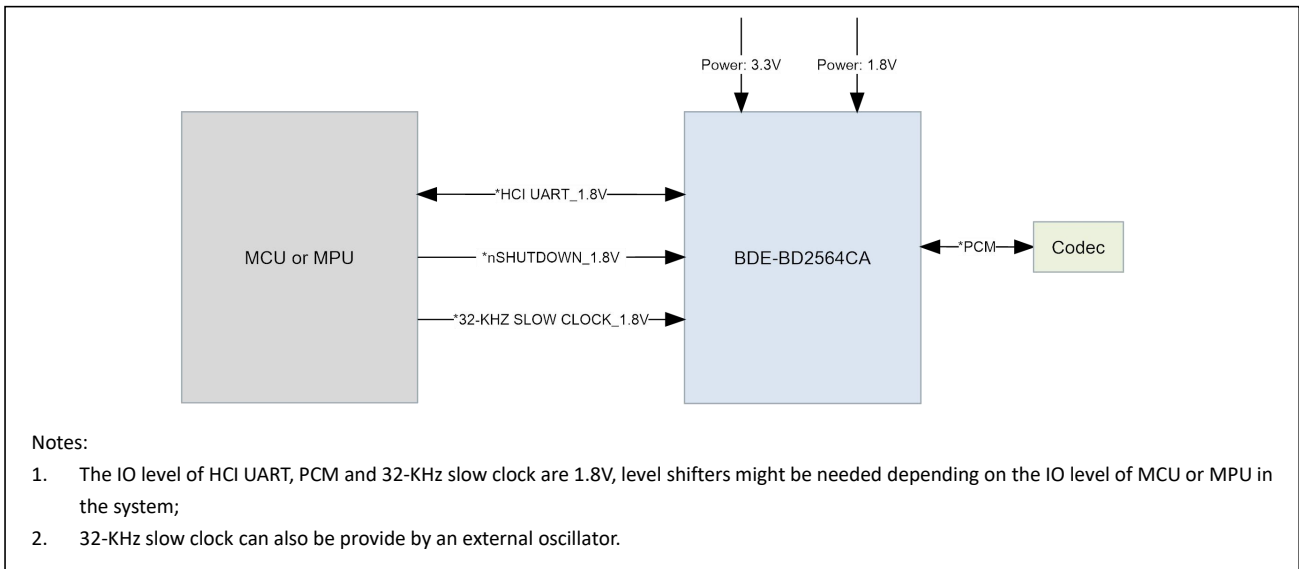

Figure 6-1. High-Level System Block Diagram

### 6.2. Reference Schematic

Below figure shows the reference schematic for integrating the module to the system. Customers can have their own part choices as long as the values and other parameters are aligned with the reference.

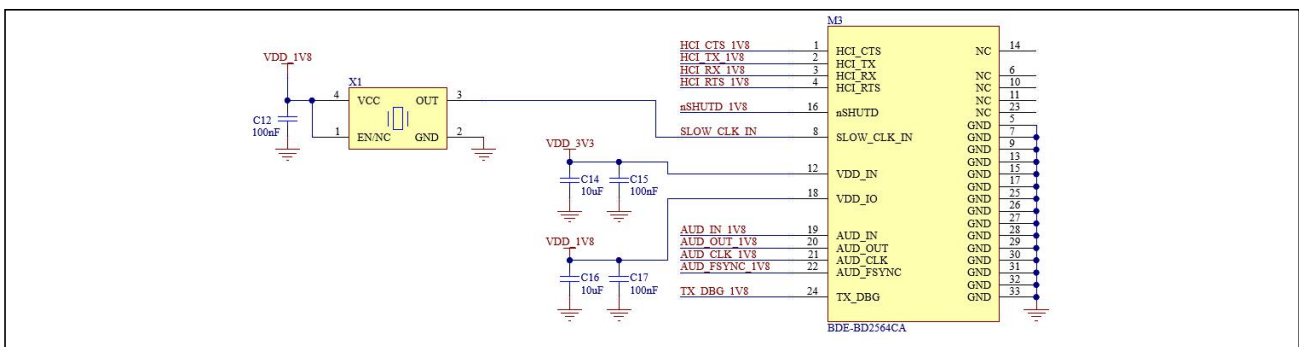

Fig 6.2. Reference schematic – part 1

The module uses 1.8V power system, level shifters need to be utilized if the application system is not 1.8V.

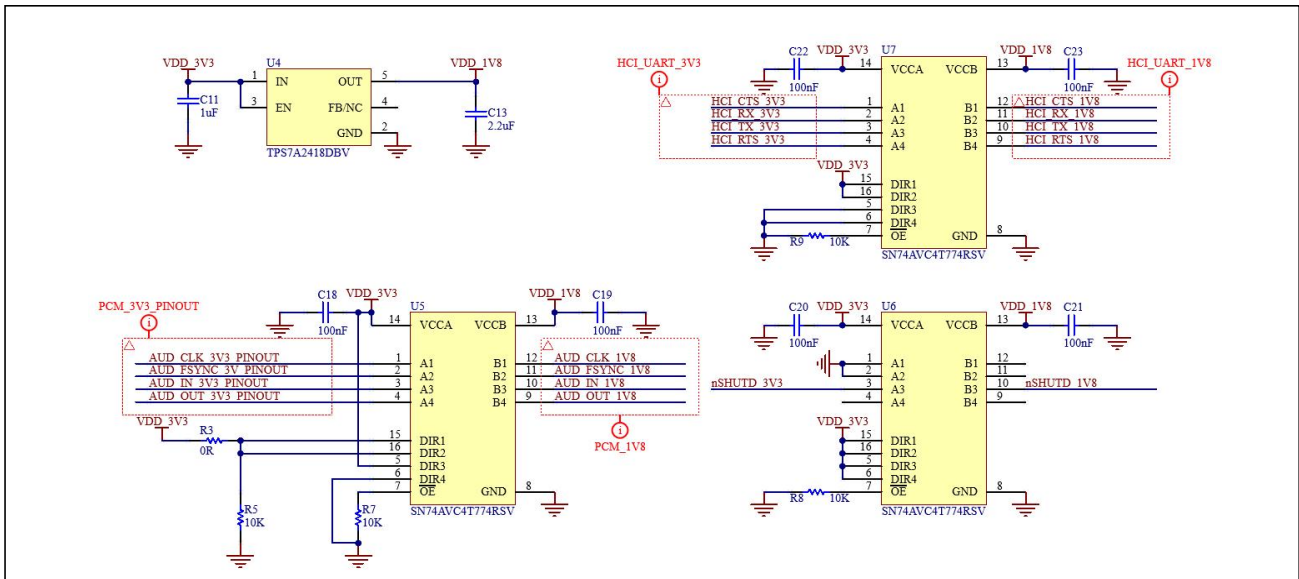

Fig 6.3. Reference schematic – part 2

### 6.3. Layout Guidelines

#### 6.3.1 General guidelines

- It is recommended to use at least four layer PCB. Below is the example of four-layer PCB stack-up based on a FR4 PCB:
  - Layer 1 (Top layer – RF + Signal)
  - Layer 2 (L2 – Ground plane)
  - Layer 3 (L3 – Power plane)
  - Layer 4 (Bottom layer - Signal)
- RF signal must be routed at layer 1.
- Decoupling capacitors must be placed as close as possible to corresponding pins of the module. And place the capacitor together on the top side. The ground connection of each capacitor must be directly connected to the solid ground (layer 2).
- Place multiple ground vias to the thermal pad of the module to increase ground coupling.
- UART lines:
  - The trace width for the UART must be at least 5 mils.
  - Run the four UART lines as a bus interface.
  - Avoid clocks, DC supply or RF traces being close the UART traces.
  - Keep solid ground on layer 2 below UART lines and also keep ground around these lines on top layer.
- PCM lines:
  - The trace width for the PCM must be at least 5 mils.
  - Run the PCM lines as the bus interface and approximately the same length.

- c) Keep solid ground on layer 2 below UART lines and also keep ground around these lines on top layer.
  - d) The trace width for the PCM must be at least 5 mils.
6. 32.768 KHz clock:
- a) The trace width of the slow clock signal must be at least 5 mils.
  - b) The trace must be as short as possible for clock signal.
  - c) Keep solid ground on layer 2 below UART lines and also keep ground around these lines on top layer.

### 6.3.2 Module Placement

The placement of the module in the base board is critical in your design. Improper placement can lead to poor antenna performance. BDE recommend following closely to below best practice placement to achieve best antenna performance.

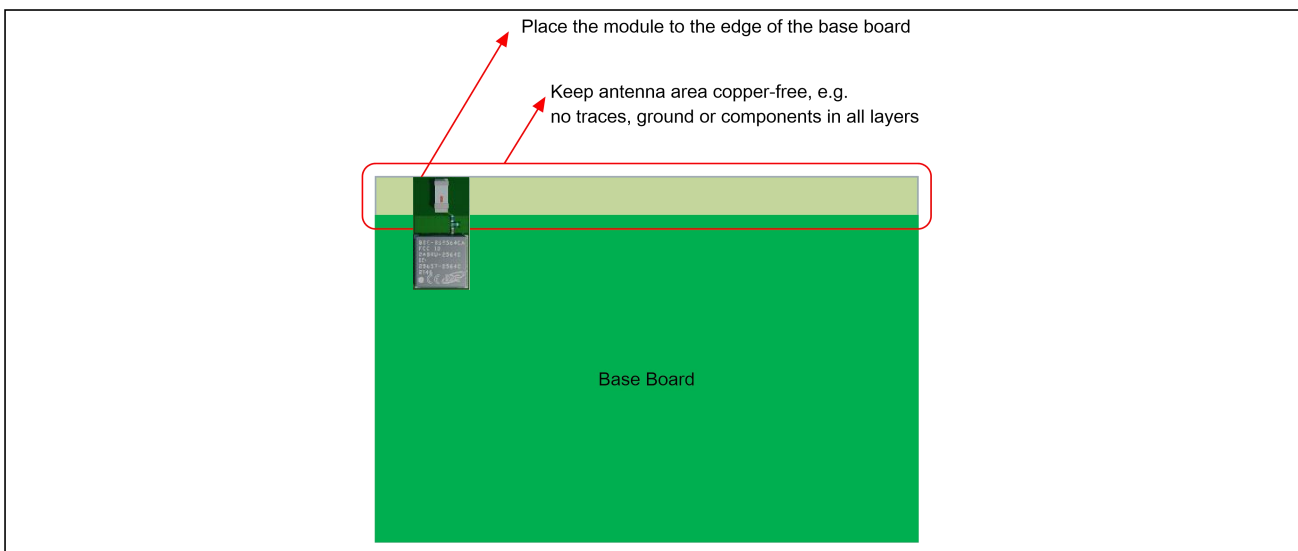

Figure 6-4. Module Placement Recommendations

## 7. Certification

### 7.1. FCC Warning and Statement

Integration instructions for host product manufacturers according to KDB 996369 D03 OEM Manual v01.

1. List of applicable FCC rules  
FCC Part 15.247

2. Specific operational use conditions

This transmitter/module and its antenna(s) must not be co-located or operating in conjunction with any transmitter. This information also extends to the host manufacturer's instruction manual.

### 3. Limited module procedures

Not applicable

### 4. Trace antenna designs

It is "not applicable" as trace antenna which is not used on the module.

### 5. RF exposure considerations

This equipment complies with FCC RF radiation exposure limits set forth for an uncontrolled environment. This compliance to FCC radiation exposure limits for an uncontrolled environment, and minimum of 20cm separation between antenna and body.

The host product manufacturer would provide the above information to end users in their end-product manuals.

### 6. Antennas

Antenna 1: Chip antenna; 0.5dBi; 2.402 GHz ~ 2.480GHz (Used in BDE-BD2564CA)

Antenna 2: Whip antenna; 2.5dBi; 2.402 GHz ~ 2.480GHz (Used in BDE-BD2564CN)

Antenna 3: Chip antenna; 0.8dBi; 2.402 GHz ~ 2.480GHz (Used in BDE-BD2564CN)

### 7. Label and compliance information

The end product must carry a physical label or shall use e-labeling followed KDB784748D01 and KDB 784748 stating "Contains Transmitter Module FCC ID: 2ABRU-BD2564C".

8. Information on test modes and additional testing requirements. For more information on testing, please contact the manufacturer.

### 9. Additional testing, Part 15 Subpart B disclaimer

The modular transmitter is only FCC authorized for the specific rule parts (FCC Part 15.247) listed on the grant, and that the host product manufacturer is responsible for compliance to any other FCC rules that apply to the host not covered by the modular transmitter grant of certification. The final host product still requires Part 15 Subpart B compliance testing with the modular transmitter installed when contains digital circuitry.

(OEM) Integrator has to assure compliance of the entire end-product incl. the integrated RF Module. For 15 B (§15.107 and if applicable §15.109) compliance, the host manufacturer is required to show compliance with 15 while the module is installed and operating.

Furthermore the module should be transmitting and the evaluation should confirm that the module's intentional emissions (15C) are compliant (fundamental / out-of-band). Finally the integrator has to apply the appropriate equipment authorization (e.g. Verification) for the new host device per definition in §15.101.

Integrator is reminded to assure that these installation instructions will not be made available to the end-user of the final host device.

The final host device, into which this RF Module is integrated" has to be labeled with an auxiliary label stating the FCC ID of the RF Module, such as "Contains FCC ID: 2ABRU-BD2564C"

This device complies with part 15 of the FCC rules. Operation is subject to the following two conditions:

(1) This device may not cause harmful interference, and

(2) This device must accept any interference received, including interference that may cause undesired operation."



"Changes or modifications to this unit not expressly approved by the party responsible for compliance could void the user's authority to operate the equipment."

The Integrator will be responsible to satisfy SAR/ RF Exposure requirements, when the module integrated into the host device.

## 7.2. IC Statement

The final host device, into which this RF Module is integrated" has to be labeled with an auxiliary label stating the IC of the RF Module, such as" Contains transmitter module IC: 25657-BD2564C

Le périphérique hôte final, dans lequel ce module RF est intégré "doit être étiqueté avec une étiquette auxiliaire indiquant le CI du module RF, tel que" Contient le module émetteur IC: 25657-BD2564C

This device contains licence-exempt transmitter(s)/receiver(s) that comply with Innovation, Science and Economic Development Canada's licence-exempt RSS(s). Operation is subject to the following two conditions:

- (1) This device may not cause interference.
- (2) This device must accept any interference, including interference that may cause undesired operation of the device.

L'émetteur/récepteur exempt de licence contenu dans le présent appareil est conforme aux CNR d'Innovation, Sciences et Développement économique Canada applicables aux appareils radio exempts de licence. L'exploitation est autorisée aux deux conditions suivantes :

- (1) L'appareil ne doit pas produire de brouillage;
- (2) L'appareil doit accepter tout brouillage radioélectrique subi, même si le brouillage est susceptible d'en compromettre le fonctionnement.

RF Exposure Warning Statements:

This equipment complies with FCC radiation exposure limits set forth for an uncontrolled environment.

This equipment shall be installed and operated with minimum distance 20cm between the radiator & body.

Radio Frequency Exposure Statement for IC:

The device has been evaluated to meet general RF exposure requirements. The device can be used in mobile exposure conditions. The min separation distance is 20cm.

Déclaration d'exposition aux radiofréquences pour IC:

L'appareil a été évalué pour répondre aux exigences générales en matière d'exposition aux RF. L'appareil peut être utilisé

dans des conditions d'exposition mobiles. La distance de séparation minimale est de 20 cm.

This radio transmitter [IC: 25657-BD2564C] has been approved by Innovation, Science and Economic Development Canada to operate with the antenna types listed below, with the maximum permissible gain indicated. Antenna types not included in this list that have a gain greater than the maximum gain indicated for any type listed are strictly prohibited for use with this device.

Cet émetteur radio [IC: 25657-BD2564C] a été approuvé par Innovation, Sciences et Développement économique Canada

pour fonctionner avec les types d'antenne énumérés ci-dessous, avec le gain maximal admissible indiqué. Les types d'antenne non inclus dans cette liste qui ont un gain supérieur au gain maximum indiqué pour tout type répertorié sont strictement interdits pour une utilisation avec cet appareil

### 7.3. Module Statement

The single-modular transmitter is a self-contained, physically delineated, component for which compliance can be demonstrated independent of the host operating conditions, and which complies with all eight requirements of § 15.212(a)(1) as summarized below.

- (1) The radio elements have the radio frequency circuitry shielded.
- (2) The module has buffered modulation/data inputs to ensure that the device will comply with Part 15 requirements with any type of input signal.
- (3) The module contains power supply regulation on the module.
- (4) The module contains a permanently attached antenna.
- (5) The module demonstrates compliance in a stand-alone configuration.
- (6) The module is labeled with its permanently affixed FCC ID label.
- (7) The module complies with all specific rules applicable to the transmitter, including all the conditions provided in the integration instructions by the grantee.
- (8) The module complies with RF exposure requirements.

NOTE: This equipment has been tested and found to comply with the limits for a Class B digital device, pursuant to part 15 of the FCC Rules. These limits are designed to provide reasonable protection against harmful interference in a residential installation. This equipment generates uses and can radiate radio frequency energy and, if not installed and used in accordance with the instructions, may cause harmful interference to radio communications. However, there is no guarantee that interference will not occur in a particular installation. If this equipment does cause harmful interference to radio or television reception, which can be determined by turning the equipment off and on, the user is encouraged to try to correct the interference by one or more of the following measures:

- Reorient or relocate the receiving antenna.
- Increase the separation between the equipment and receiver.
- Connect the equipment into an outlet on a circuit different from that to which the receiver is connected.
- Consult the dealer or an experienced radio/TV technician for help

## 8. Ordering Information

Part Number	Description	Size (mm)	Package	MOQ
BDE-BD2564CA	Bluetooth 5.1 Dual Mode Transceiver Module	7 × 14 × 1.55	Tape & Reel	1000

## 9. Revision History

Revision	Date	Description
V1.0	17-July-2021	Initial Release, brief
V2.0	27-Dec-2021	Change Module's name
V2.1	18-Jan-2022	Added Detail data
V2.2	30-Aug-2022	Added Certification Information
V2.3	23-Jan-2024	Correct ISED ID in Figure 5-1

You can find the latest documentation in this [Link](#)

## Important Notice and Disclaimer

The information contained herein is believed to be reliable. BDE makes no warranties regarding the information contained herein. BDE assumes no responsibility or liability whatsoever for any of the information contained herein. BDE assumes no responsibility or liability whatsoever for the use of the information contained herein. The information contained herein is provided "AS IS, WHERE IS" and with all faults, and the entire risk associated with such information is entirely with the user. All information contained herein is subject to change without notice. Customers should obtain and verify the latest relevant information before placing orders for BDE products. The information contained herein or any use of such information does not grant, explicitly or implicitly, to any party any patent rights, licenses, or any other intellectual property rights, whether with regard to such information itself or anything described by such information.

## Contact

### BDE Technology Inc.

USA: 67 E Madison St, # 1603A, Chicago, IL 60603, US

Tel: +1-312-379-9589

Website: <http://www.bdecomm.com>

Email: [info@bdecomm.com](mailto:info@bdecomm.com)

China: B2-403, 162 Science Avenue, Huangpu District, Guangzhou 510663, China

Tel: +86-20-28065335

Website: <http://www.bdecomm.com>

Email: [shu@bdecomm.com](mailto:shu@bdecomm.com)